



Turboschwader

Ersatzteilliste

Instructions de Service et Liste des Pièces de Rechange
Operating Instructions and Spare Parts List
Istruzioni sull'uso e distina delle parti di ricambio
Gebruiksaanwijzing en Onderdeelenlist
Bruksanvisning och Reservdelslista

TS 630 Hydro

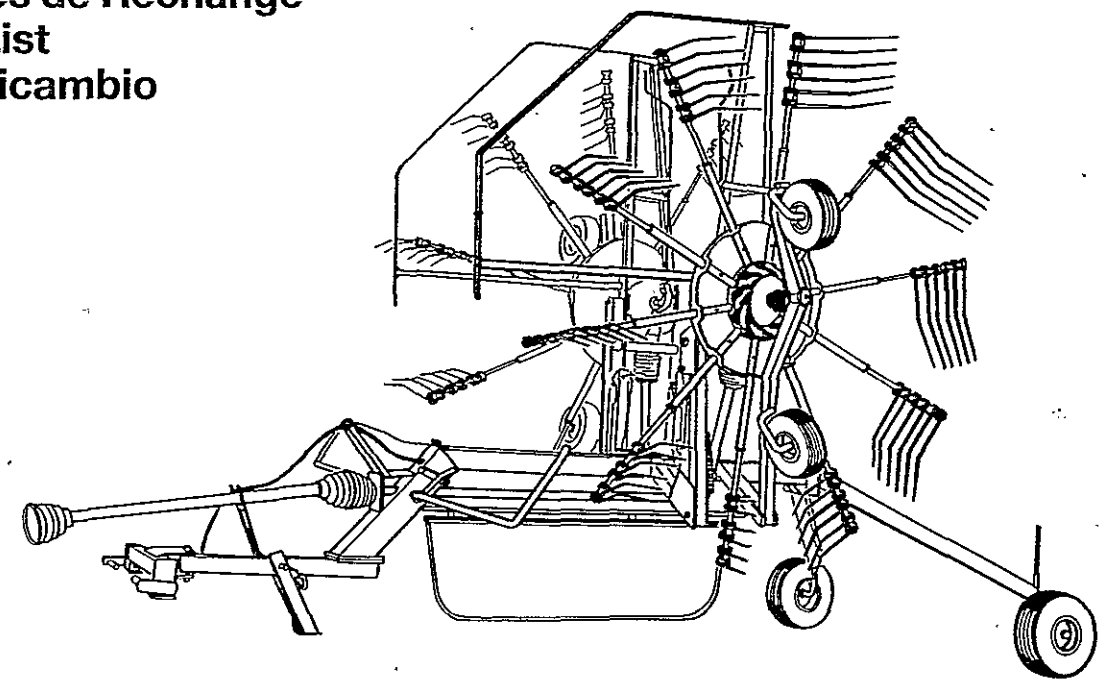

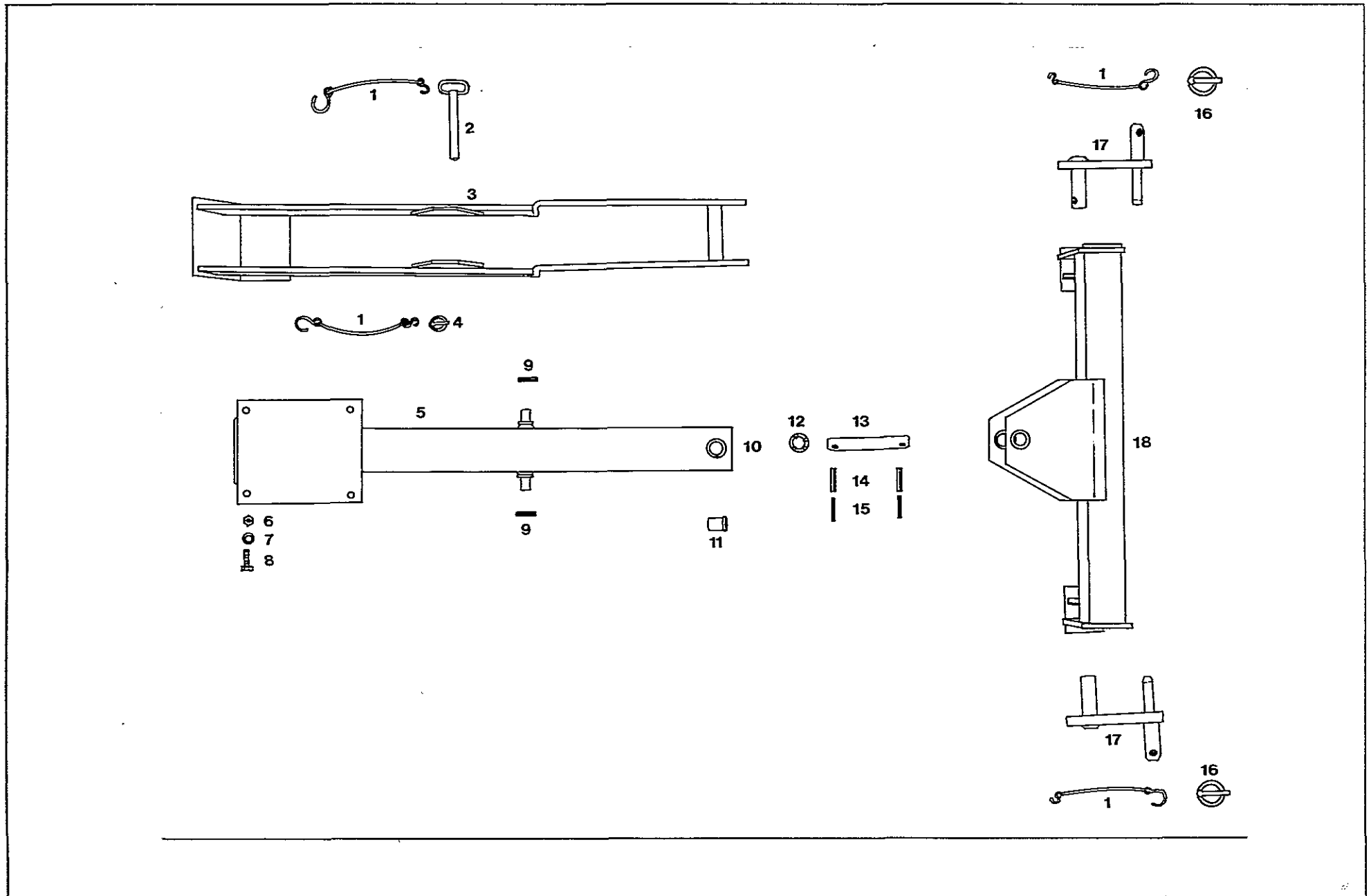

Pos.Nr.	Bezeichnung des Teiles	X = Verschleißteil	* = kein Ersatzteil	Nr.			
Pos.no.	Description of the part	X = weare part	* = no spare part	No.			
Rep.	Désignation de la pièce	X = pièces d'usure	* = no pièce de rechange	No.			
Pos. no.	Descrizione del pezzo			No.	TS 630		
	Deichsel		Drawbar				
							Timon
1	Sicherungsschnur		Safety cord	111 895	X		
2	Steckbolzen		Stud pin	486 195	●		
3	Stützfuß		Support	492 942	●		
4	Klappstecker 5 DIN 11023		Folding plug	109 162	X		
5	Deichsel		Drawbar	492 954	●		
6	6kt.-Mutter M 16 DIN 6925-8 A1A		Hexagonal nut	116 699	●		
7	Scheibe 17 DIN 125 ZN 3		Washer	115 979	●		
8	6kt.-Schraube M 16x45 DIN 933-8.8 A1A		Hexagonal bolt	116 587	●		
9	Spannstift 6x40 DIN 1481 ZN 3		Tension pin	107 452	●		
10	Kegelschmiernippel AS 8x1 DIN 71412		Conical grease nipple	108 292	●		
11	Buchse		Bush	121 024	●		
12	Stützscheibe 28x40x2 DIN 988 ZN 3		Support plate	126 929	●		
13	Bolzen		Bolt	122 353	●		
14	Spannstift 8x45 DIN 1481 ZN 3		Tension pin	126 880	●		
15	Spannstift 5x45 DIN 1481 ZN 3		Tension pin	126 881	●		
16	Klappstecker 12 DIN 11023		Folding plug	108 544	X		
17	Unterlenkerlasche		Lower link tongue	492 385	●		
18	Unterlenkerschiene		Lower link rail	492 945	●		

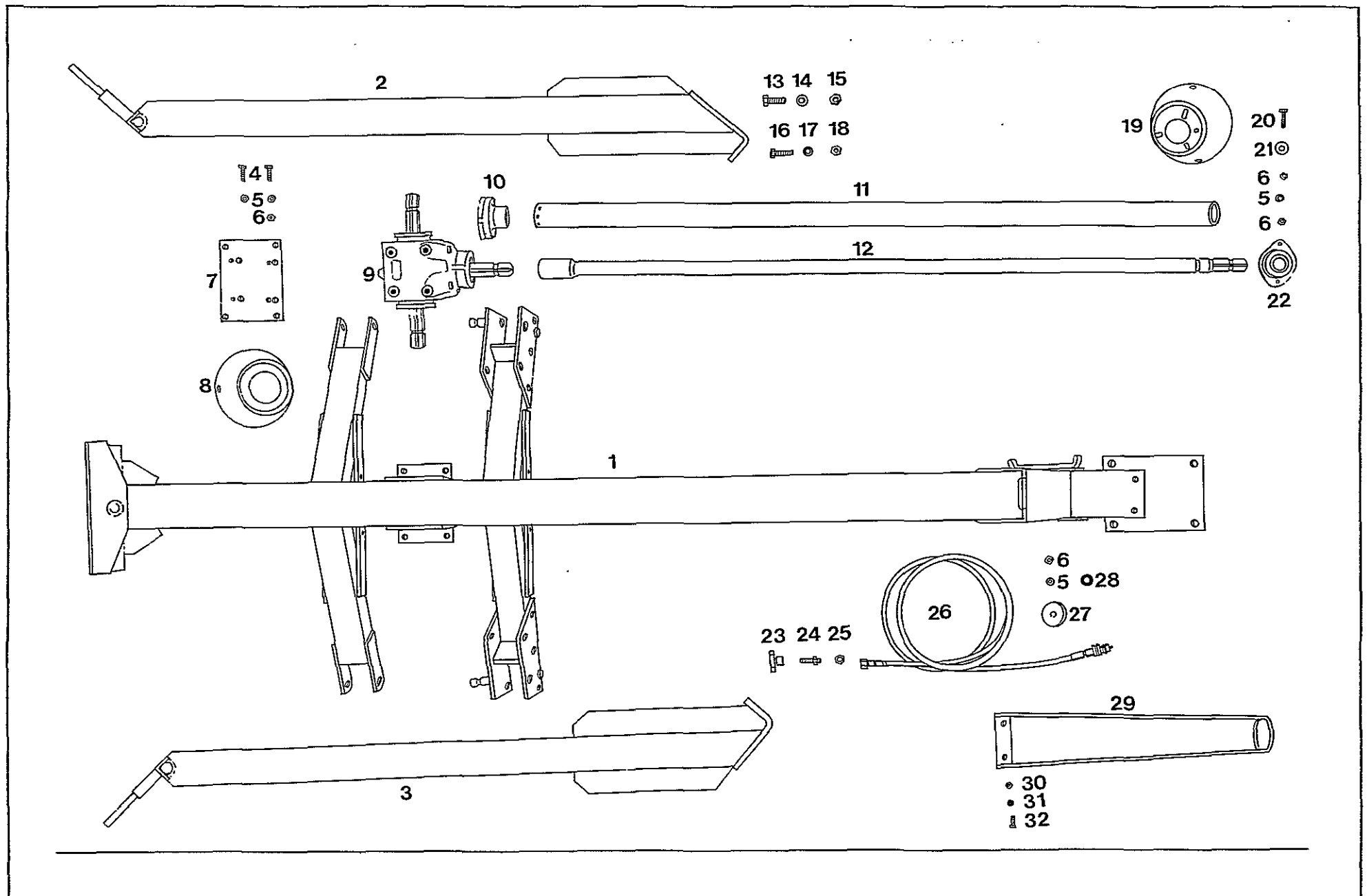

Pos.Nr.	Bezeichnung des Teiles	X = Verschleißteil	* = kein Ersatzteil	Nr.			
Pos.no.	Description of the part.	X = wear part	* = no spare part	No.	TS 630		
Rep.	Désignation de la pièce	X = pièces d'usure	* = no pièce de rechange	No.			
Pos. no.	Descrizione del pezzo			No.			
	Rahmen		Frame				Châssis
1	Rahmen		Frame	497 092	•		Châssis
2	Ausleger, links		Outrigger left	492 857	•		Bras levier gauche
3	Ausleger, rechts		Outrigger right	492 856	•		Bras levier droit
4	6kt.-Schraube M 10x30 DIN 933-8.8 A1A verbus-plus		Hexagonal bolt	126 137	•		Vis à 6 pans
5	Scheibe 11 DIN 126 ZN 3		Washer	115 983	•		Rondelle
6	Sicherungsmutter M 10 DIN 6925-8 A1A		retaining nut	108 441	•		Ecrou de maintien
7	Platte		Plate	497 050	•		Plaque
8	Schutztopf GT 30 502 287 *		Guard *				Protection *
9	Getriebe * (*)		Gearbox * (*)	122 491			Engrenage *(*)
10	Schutzrohrhalter		Guard tube support	122 511	•		Support de tube protection
11	Schutzrohr		Guard tube	122 442	•		Tube protection
12	Verlängerungswelle		Extension shaft	492 903	•		Essieu d'allongement
13	6kt.-Schraube M 16x45 DIN 933-8.8 A1A		Hexagonal bolt	116 587	•		Vis à 6 pans
14	Scheibe 17 DIN 125 ZN 3		Washer	115 979	•		Rondelle
15	6kt.-Mutter M 16 DIN 6925-8 A1A		Hexagonal nut	116 699	•		Ecrou à 6 pans
16	6kt.-Schraube M 12x40 DIN 933-8.8 A1A		Hexagonal bolt	116 630	•		Vis à 6 pans
17	Scheibe 13 DIN 125 ZN 3		Washer	105 186	•		Rondelle
18	6kt.-Mutter M 12 DIN 6925-8 A1A		Hexagonal nut	105 189	•		Ecrou à 6 pans
19	Gelenkwellenschutz		P.t.o.-Shaft guard	486 050	•		Protection de l'arbre de transm.
20	6kt.-Schraube M 10x40 DIN 933-8.8 A1A		Hexagonal bolt	117 772	•		Vis à 6 pans
21	Scheibe 11 DIN 440 ZN 3		Washer	116 007	•		Rondelle
22	Flanschgehäuse		Socket box	117 430	•		Boîtier de la bride
23	Einstellbare T-Verschraubung		Adjustable bolting	126 926	•		Vissage réglable
24	Gerade Schottverschraubung		Straight bolting	126 927	•		Plat vissage
25	6kt.-Mutter M 14x1,5 DIN 934-8 A1A		Hexagonal nut	109 175	•		Ecrou à 6 pans
26	Hydraulikschlauch		Hydraulic hose	122 500	X		Tuyau hydraulique
27	Anschlagpuffer		Bumper	122 205	•		Tampon
28	Kurbeldurchführungsstülle		Seal	122 471	•		Bague
29	Schlauchhalter		Support	497 091	•		Support
30	6kt.-Mutter M 8 DIN 6925-8 A1A		Hexagonal nut	108 531	•		Ecrou à 6 pans
31	Scheibe 8,4 DIN 125 ZN 3		Washer	115 972	•		Rondelle
32	6kt.-Schraube M 8x25 DIN 933-8.8 A1A		Hexagonal bolt	116 614	•		Vis à 6 pans
*Ersatzteile können nur durch die Fa. Walterscheid bezogen werden.		*Spare parts can only be purchased from the Walterscheid company.		*Les pièces de rechange peuvent seulement être achetées de chez la maison Walterscheid.			
(*) siehe Tafel 8		(*) Table 8		(*) Plan 8			

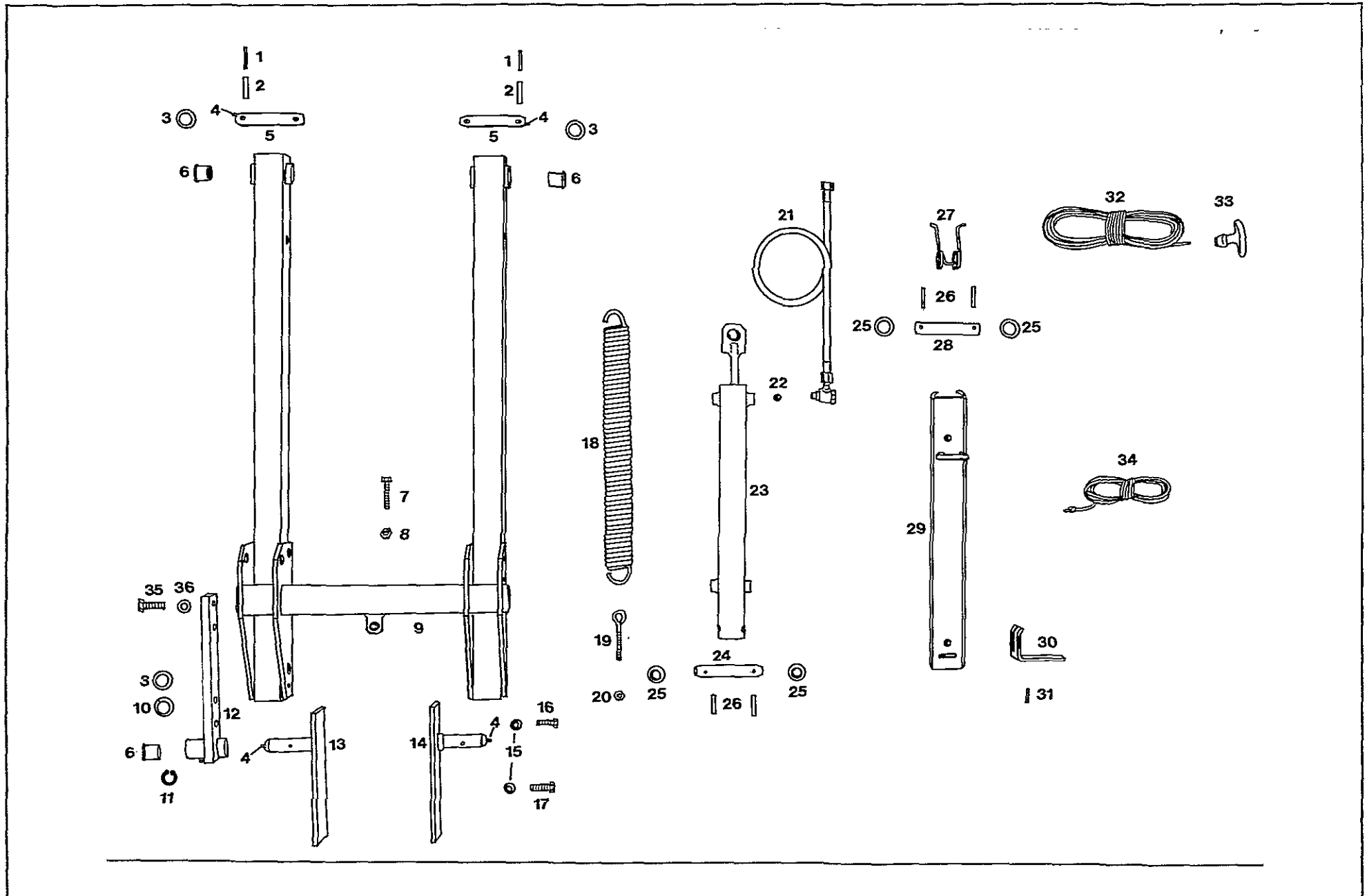

Pos.Nr.	Bezeichnung des Teiles	X = Verschleißteil	* = kein Ersatzteil	Nr.			
Pos.no.	Description of the part.	X = wear part	* = no spare part	No.			
Rep.	Désignation de la pièce	X = pièces d'usure	* = no pièce de rechange	No.			
Pos. no.	Descrizione del pezzo			No.			
	Schwenkarm, Hydraulik		Pivoting arm, hydraulic				Bras pivotante, hydraulique
1	Spannstift 8x45 DIN 1481 ZN 3		Tension pin	126 880	●		Goupille
2	Spannstift 5x45 DIN 1481 ZN 3		Tension pin	126 881	●		Goupille
3	Stützscheibe 28x40x2 DIN 988		Support plate	126 929	●		Rondelle de support
4	Kegelschmiernippel		Conical grease nipple	108 294	●		Graisseur conique
5	Bolzen		Bolt	122 334	●		Boulon
6	Buchse		Bush	121 024	●		Douille
7	6kt.-Schraube M 12x60 DIN 933-8.8 A1A		Hexagonal bolt	117 726	●		Vis à 6 pans
8	6kt.-Mutter M 12 DIN 934-8 A1A		Hexagonal nut	116 686	●		Ecrou à 6 pans
9	Schwenkarm		Pivoting arm	492 870	●		Bras pivotante
10	Scheibe		Washer	224 473	●		Rondelle
11	Sicherungsring 28x2 DIN 471		Snap ring	118 973	●		Circlip extérieur
12	Einstelliasche		Tongue	492 569	●		Eclisse
13	Scharnierstück, links		Hinge piece, left	492 884	●		Pièce de charnière, gauche
14	Scharnierstück, rechts		Hinge piece, right	492 883	●		Pièce de charnière, droit
15	Scheibe 13 DIN 125 ZN 3		Washer	105 186	●		Rondelle
16	6kt.-Schraube M 12x30 DIN 933-10.9 A1A verbus-plus		Hexagonal bolt	126 308	●		Vis à 6 pans
17	6kt.-Schraube M 12x40 DIN 933-10.9 A1A verbus-plus		Hexagonal bolt	126 383	●		Vis à 6 pans
18	Zugfeder		Pulling spring	122 294	●		Ressort de tension
19	Üsenschraube		Eyebolt	122 469	●		Vis à oeil
20	Sicherungsmutter M 8 DIN 6925 A1A		Retaining nut	108 531	●		Ecrou de maintien
21	Hydraulikschlauch		Hydraulic hose	122 501	X		Tuyau hydraulique
22	Drossel		Stop	478 677	●		Arrêt
23	Hydraulikzylinder		Hydraulic cylinder	122 150	●		Vérin hydraulique
24	Bolzen		Bolt	122 333	●		Boulon
25	Scheibe 26 DIN 1441 ZN 3		Washer	109 171	●		Rondelle
26	Spannstift 6x40 DIN 1481 ZN 3		Tension pin	107 452	●		Goupille
27	Schenkelfeder		Spring	122 494	●		Ressort
28	Bolzen		Bolt	122 335	●		Boulon
29	Rastprofil		Locking profile	492 891	●		Profil de verrouillage
30	Hebel		Lever	492 887	●		Levier
31	Spannstift 5x24 DIN 1481 ZN 3		Tension pin	107 435	●		Goupille
32	Spannseil 5000 mm		Tension rope	121 094	X		Câble de serrage
33	Knebelgriff		Handle	120 957	●		Manette de flèche
34	Spannseil 2500 mm		Tension rope	121 801	X		Câble de serrage
35	6kt.-Schraube M 16x40 DIN 933-8.8 A1A verbus-plus		Hexagonal bolt	126 377	●		Vis à 6 pans
36	Scheibe 17 DIN 125 ZN 3		Washer	115 979	●		Rondelle

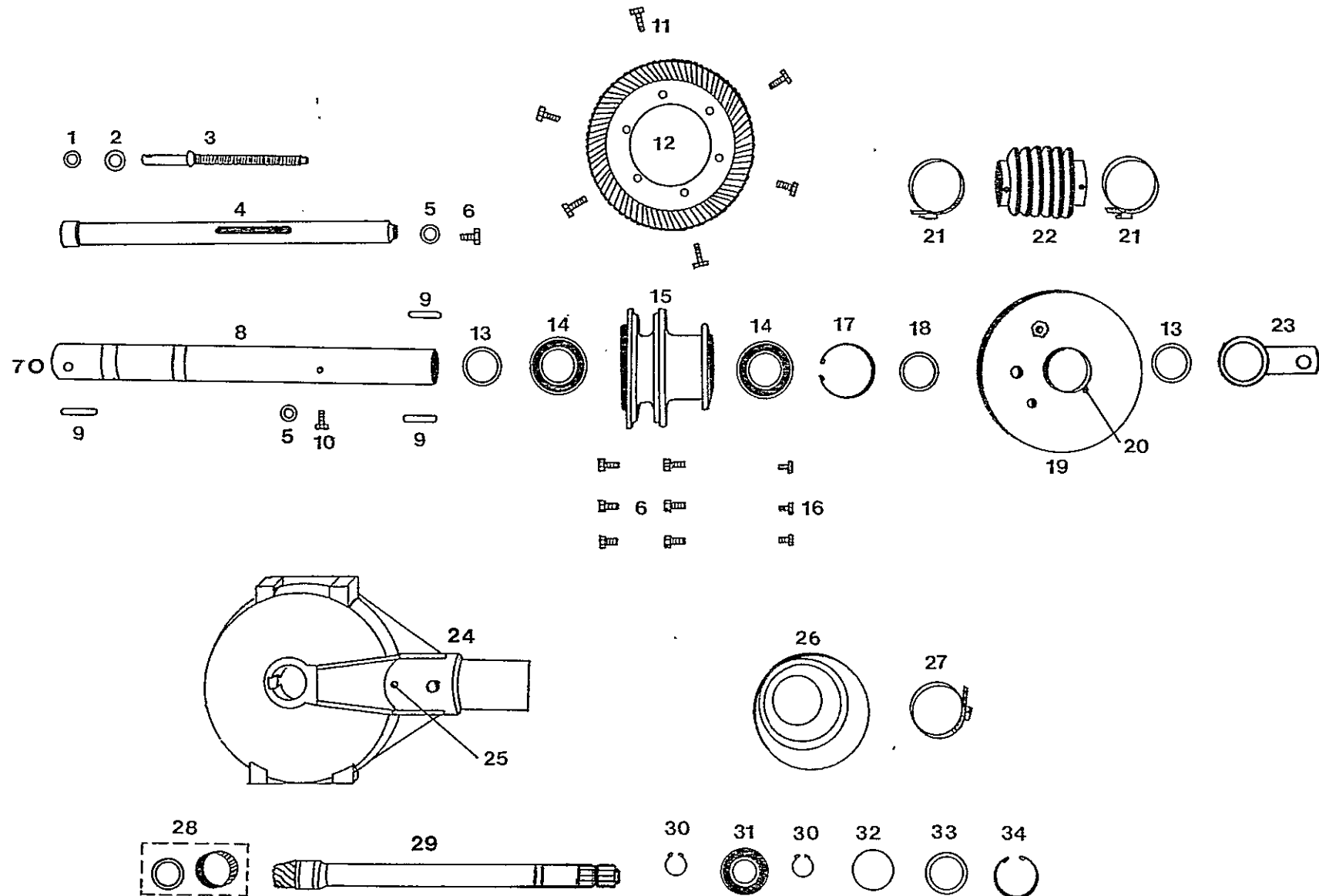

Pos.Nr.	Bezeichnung des Teiles	X = Verschleißteil	* = kein Ersatzteil	Nr.			
Pos.no.	Description of the part.	X = weare part	* = no spare part	No.			
Rep.	Désignation de la pièce	X = pièces d'usure	* = no pièce de rechange	No.			
Pos. no.	Descrizione del pezzo			No.			
	Antrieb, Getriebewelle		Drive power, gear shaft				Entraînement, arbre de transmission
1	Scheibe 19 DIN 1441		Washer	116 024	●		Rondelle
2	Axial-Rillenkugellager 51104 DIN 711		Grooved ball bearing	124 131	●		Roulement rainuré à billes
3	Spindel		Spindle	492 886	●		Pivot
4	Hubstange		Lifting bar	492 879	●		Barre de levage
5	Scheibe 13 DIN 125 ZN 3		Washer	105 186	●		Rondelle
6	6kt.-Schraube M 12x30 DIN 933-10.9 A1A		Hexagonal bolt	126 308	●		Vis à 6 pans
7	Runddichtring 17x3,5 DIN 3770 NB 70		Round seal	126 417	●		Bague ronde
8	Kreiselachse		Rotor axle	497 027	●		Plateau de axe
9	Paßfeder A 12x8x56 DIN 6885 C 45 K+V		Fitting spring	108 319	●		Ressort de fixation
10	Zylinderschraube		Intermediate pipe	122 079	●		Tube intermédiaire
11	Zylinderschraube M12x30 DIN7984-8.8A1A Verbus-plus		Intermediate pipe	126 303	●		Tube intermédiaire
12	Tellerrad, links		Rim gear, left	121 914	●		Roue, gauche
12	Tellerrad, rechts		Rim gear, right	121 349	●		Roue, droite
13	Paßscheibe 60x75x0,3 DIN 988 (n. Bedarf)		Fitting plate	126 384	●		Rondelle de fixation
13	Paßscheibe 60x75x0,5 DIN 988 (n. Bedarf)		Fitting plate	126 385	●		Rondelle de fixation
13	Paßscheibe 60x75x0,1 DIN 988 (n. Bedarf)		Fitting plate	124 650	●		Rondelle de fixation
14	Rillenkugellager 6012-2 RS DIN 625		Grooved ball bearing	118 604	●		Roulement rainuré à billes
15	Nabe		Hub	492 255	●		Moyeu
16	6kt.-Schraube M 12x20 DIN 933-8.8 A1A Verbus-plus		Hexagonal bolt	124 331	●		Vis à 6 pans
17	Sicherungsring 95x3 DIN 472		Snap ring	116 043	●		Circlip intérieur
18	Stützscheibe 60x75x3 DIN 988		Support plate	126 302	●		Rondelle de support
19	Kurvenscheibe		Cam plate	492 934	●		Chemise de roulement
20	Schmiernippel AS 8x1 DIN 71412		Grease nipple	108 292	●		Graisseur
21	Schlauchschele SA 70x90 SKZ DIN 3017		Hose clip	117 831	●		Collier pour chambre à air
22	Faltenbalg		Bellows	121 990	●		Accordéon
23	Buchse		Bush	492 377	●		Douille
24	Rahmen		Frame	492 907	●		Châssis
25	Schmiernippel BS 8x1 DIN 71412		Grease nipple	116 746	●		Graisseur
26	Gelenkwellenschutz 82.84.05		P.t.o.-shaft guard		●		Protecteur de l'arbre de transm.
	Bezug nur durch Fa. Walterscheid		This part can only be purchased from the Walterscheid company				Les pièces peuvent seulement être achetées de chez la maison Walterscheid.
27	Schlauchschele SA 70-90 SKZ DIN 3017		Hose clip	117 831	●		Collier pour chambre à air
28	Nadellager HK 5024 2 RS AS 1 mit Innenring 121335		Pin bearing	497 131	●		Roulement à aiguilles
29	Getriebewelle, rechts		Gear shaft, right	492 901	●		Arbre d'entraînement, droit
29	Getriebewelle, links		Gear shaft, left	492 900	●		Arbre d'entraînement, gauche
30	Sicherungsring A 35x2,5 DIN 471		Snap ring	118 602	●		Circlip extérieur
31	Rillenkugellager 6207 2 RS C3 DIN 625		Grooved ball bearing	109 585	●		Roulement rainuré à billes
32	Stützscheibe 56x72x3 DIN 988		Support plate	124 151	●		Rondelle de support
32	Paßscheibe 56x72x0,3 DIN 988 (n. Bedarf)		Fitting plate	126 368	●		Rondelle de fixation
32	Paßscheibe 56x72x0,5 DIN 988 (n. Bedarf)		Fitting plate	126 369	●		Rondelle de fixation
32	Paßscheibe 56x72x1,0 DIN 988 (n. Bedarf)		Fitting plate	126 370	●		Rondelle de fixation
33	Ring		Ring	490 920	●		Circlip
34	Sicherungsring 72x2,5 DIN 472		Snap ring	107 385	●		Circlip intérieur

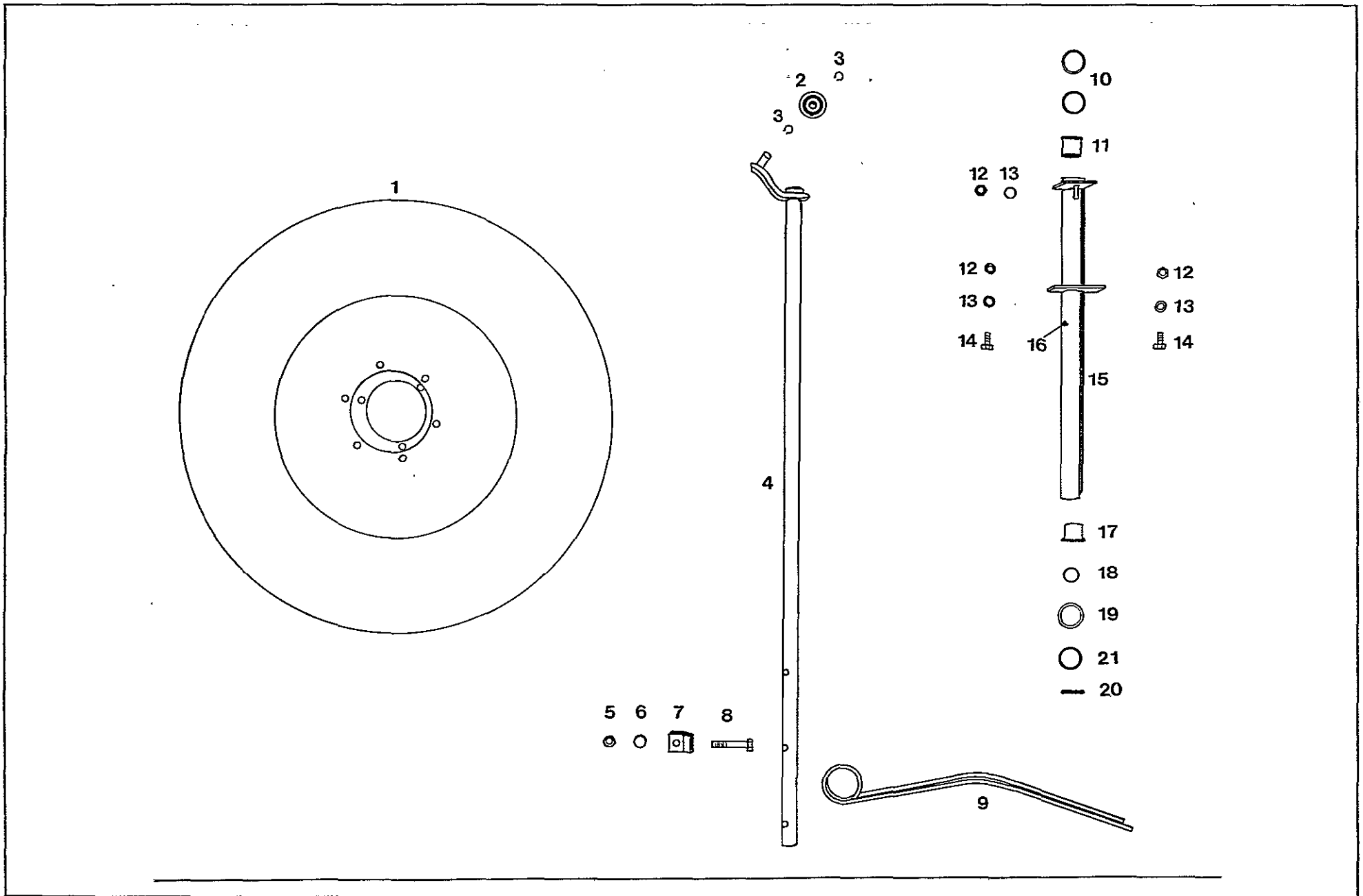

Pos.Nr.	Bezeichnung des Teiles	X = Verschleißteil	* = kein Ersatzteil	Nr.			
Pos.no.	Description of the part	X = weare part	* = no spare part	No.			
Rep.	Désignation de la pièce	X = pièces d'usure	* = no pièce de rechange	No.			
Pos. no.	Descrizione del pezzo			No.			
	Glocke, Zinkenträger, Lagerrohr		Dome, tine arm, tube				
	Cloche, toupie, bourreau						
1	Glocke		Dome	492 324	●		
2	Kurvenrolle, vollst.		Cam roller, cpl.	497 122	X		
3	Sicherungsring 15x1,5 DIN 471		Snap ring	124 749	●		
4	Zinkenträger, rechts		Tine arm, right	497 058	●		
4	Zinkenträger, links		Tine arm, left	492 329	●		
5	Sicherungsmutter M 12 DIN 6925-8 A1A		Retaining nut	108 589	●		
6	Unterlage		Support	486 545	●		
7	Zinkenhalter		Tine arm	486 848	●		
8	6kt.-Schraube M 12x70 DIN 631-8.8 verz.		Hexagonal bolt	116 534	●		
9	Federzinken		Flexible tine	497 032	X		
10	Scheibe		Fitting plate	086 184	●		
11	Lagerbuchse m. Rand PA 6 n. DIN 7728 GV 30 + MOS 2		Bush	490 072	●		
12	6kt.-Mutter M 12 DIN 6925-8 A1A		Hexagonal nut	108 589	●		
13	Scheibe 13 DIN 125 ZN 3		Washer	105 186	●		
14	6kt.-Schraube M 12x25 DIN 933-8.8 A1A		Hexagonal bolt	116 627	●		
15	Lagerrohr		Tube	492 330	●		
16	Schmiernippel AS 8x1x3,5		Grease nipple	124 608	●		
17	Lagerbuchse m. Rand PA 6 n. DIN 7728 GV 30 + MOS 2		Bush	120 725	●		
18	Runddichtring 30x2,5 DIN 3770 - NB 70		Round seal	106 990	●		
19	Staubkappe		Dustcap	490 961	●		
20	Spannstift 6x50 DIN 1481 ZN 3		Tension pin	107 454	●		
21	Paßscheibe 35x45x1 DIN 988 ZN 3		Fitting plate	120 595	●		

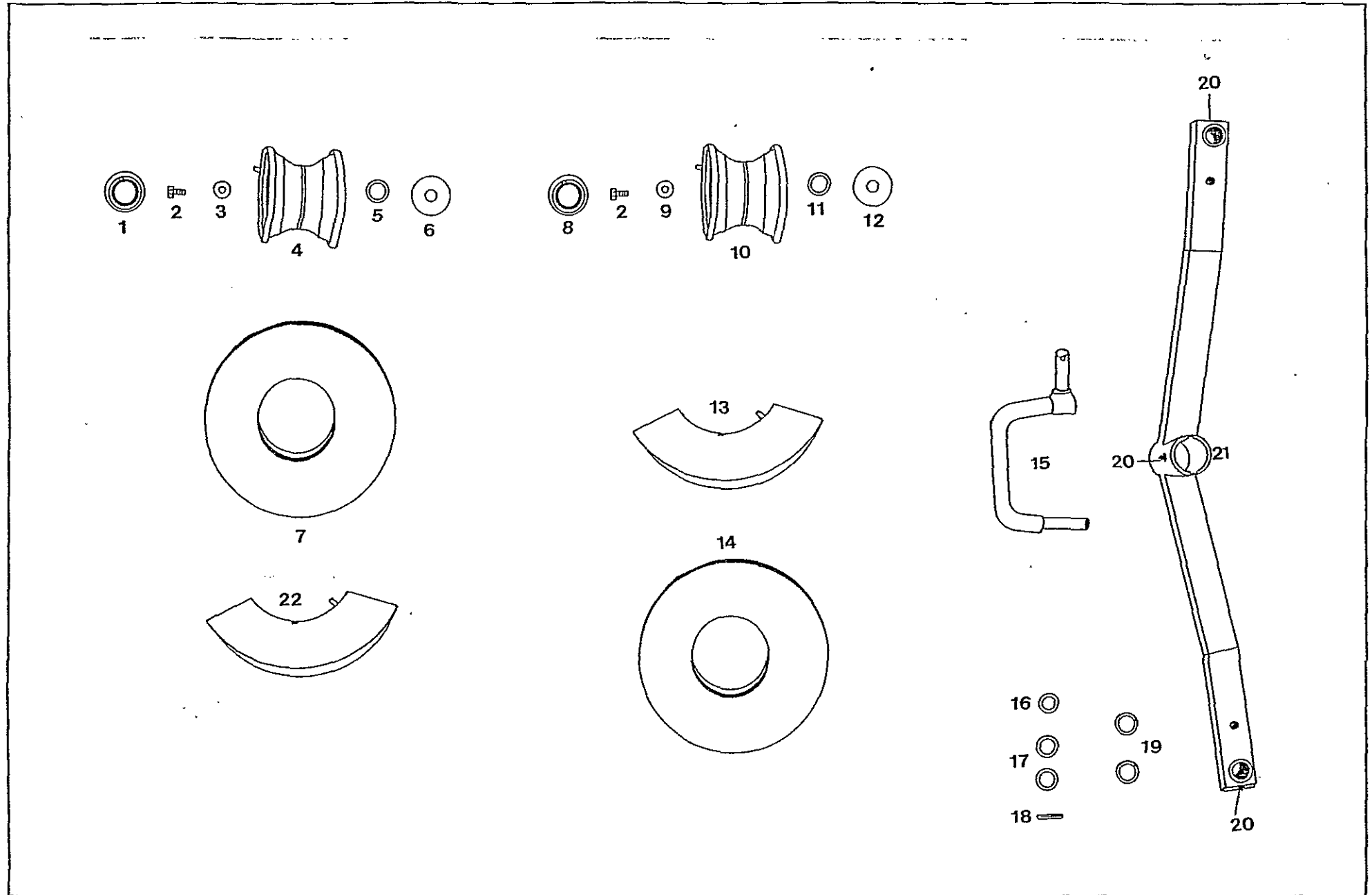

Pos.Nr.	Bezeichnung des Teiles	X = Verschleißteil	* = kein Ersatzteil	Nr.			
Pos.no.	Description of the part	X = weare part	* = no spare part	No.			
Rep.	Désignation de la pièce	X = pièces d'usure	* = no pièce de rechange	No.			
Pos.no.	Descrizione del pezzo			No.			
	Achsen und Laufräder		Axle and track wheel				
							Axe et roue
1	Abschlußkappe		Sealing hat	126 920	●		
2	6kt.-Schraube M 12x20 DIN 933-8.8 A1A		Hexagonal bolt	124 331	●		
3	Scheibe		Washer	460 262	●		
4	Felge 6.00 Jx15 ^{41.}		Rim	122 477	●		
5	Paßscheibe 30x42x2 DIN 988		Fitting plate	116 015	●		
6	Schutzscheibe, hinten		Rear protective plate	497 028	●		
7	Decke 215/65-15/6 PR Ri CS		Surface	126 921	X		
8	Abschlußkappe		Sealing hat	121 327	●		
9	Scheibe		Washer	464 006	●		
10	Felge 4.50 A x 6 m. 2 Rillenkugellager 6205-2 RS		Rim with grooved ball bearing	121 608	●		
11	Scheibe		Washer	240 309	●		
12	Schutzscheibe, hinten		Rear protective plate	488 456	●		
13	Schlauch 140-6 TR 13		Tube	121 610	X		
14	Decke 15x6.00-6 Impl. 4 PR-T510 ^{41.}		Surface	121 609	X		
15	Laufachse		Carrying axle	492 271	●		
16	Buchse		Bush	122 460	●		
17	Scheibe		Washer	224 473	●		
18	Spannstift 8x40 DIN 1481		Tension pin	107 465	●		
19	Buchse		Bush	121 024	●		
20	Schmiernippel AM 8x1 DIN 71412 SFG		Grease nipple	108 292	●		
21	Achse		Axle	492 881	●		
22	Schlauch 215/65-15		Tube	127 006	X		

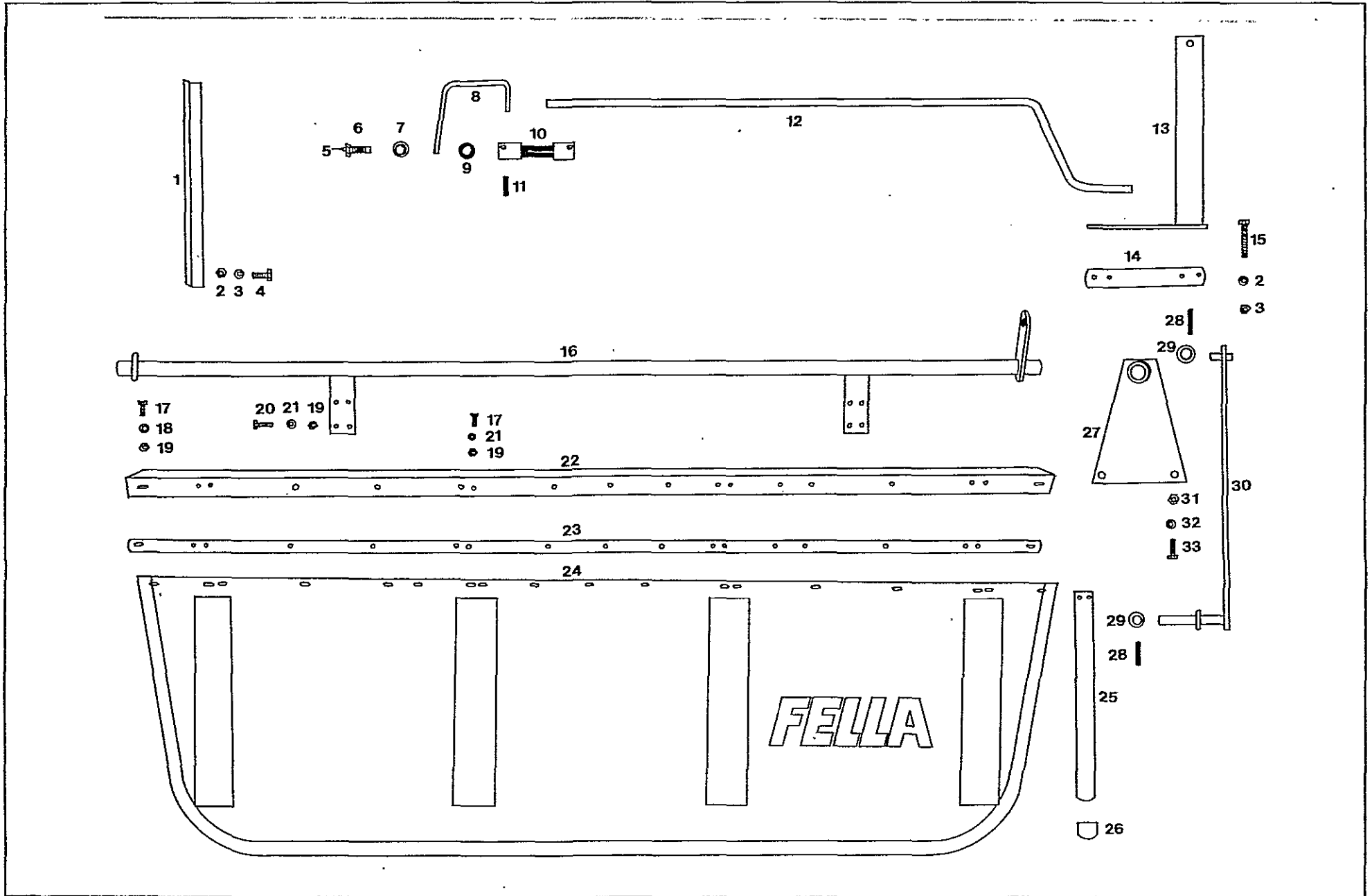

Pos.Nr. Pos.no. Rep. Pos. no.	Bezeichnung des Teiles Description of the part Désignation de la pièce Descrizione del pezzo	X = Verschleißteil X = wear part X = pièces d'usure	* = kein Ersatzteil * = no spare part * = no pièce de rechange	Nr. No. No. No.	TS 630			
	Schwadformer, Kurbel		Swathformer, crank					
	Mouleur d'andains, manivelle							
1	Halter für Beleuchtung		Support	492 892	●			
2	6kt.-Mutter M 8 DIN 6925-8 A1A		Hexagonal nut	108 531	●			
3	Scheibe 8,4 DIN 125 ZN 3		Washer	115 972	●			
4	6kt.-Schraube M 8x16 DIN 933-8.8 A1A		Hexagonal bolt	116 612	●			
5	Kegelschmiernippel AS 8x1 DIN 71412		Conical grease nipple	108 292	●			
6	6kt.-Schraube		Hexagonal bolt	492 361	●			
7	Scheibe 17 DIN 125 ZN 3		Washer	115 979	●			
8	Kurbelhalter		Crank holder	497 082	●			
9	Scheibe 19 DIN 1441		Washer	116 024	●			
10	Biegsame Welle		Flexible shaft	121 970	●			
11	Spannstift 8x36 DIN 1481 ZN 3		Tension pin	107 464	●			
12	Kurbel		Crank	492 862	●			
13	Kurbelhalter		Crank holder	492 913	●			
14	Lasche		Tongue	492 916	●			
15	6kt.-Schraube M 8x70 DIN 931-8.8 A1A		Hexagonal bolt	124 279	●			
16	Führungsrohr		Guide tube	497 044	●			
17	6kt.-Schraube M 6x20 DIN 933-8.8 A1A		Hexagonal bolt	116 608	●			
18	Scheibe 6,4 DIN 9021 ZN 3		Washer	124 512	●			
19	6kt.-Mutter M 6 DIN 985-8 A1A		Hexagonal nut	106 903	●			
20	6kt.-Schraube M 6x25 DIN 933-8.8 A1A		Hexagonal bolt	116 609	●			
21	Scheibe 6,4 DIN 125 ZN 3		Washer	115 970	●			
22	Träger		Carrier	492 299	●			
23	Klemmleiste		Spacer	492 298	●			
24	Schwadtuch		Cloth	121 968	X			
25	Flachfeder		Flat spring	121 612	●			
26	Schutzkappe		Protective cap	122 103	●			
27	Führung		Bracket	497 043	●			
28	Spannstift 6x40 DIN 1481 ZN 3		Tension pin	107 452	●			
29	Scheibe 21 DIN 125 ZN 3		Washer	108 455	●			
30	Gestänge		Bar	497 047	●			
31	6kt.-Mutter M 10 DIN 6925-8 A1A		Hexagonal nut	108 441	●			
32	Scheibe 11 DIN 125 ZN 3		Washer	115 983	●			
33	6kt.-Schraube M 10x30 DIN 933-8.8 A1A		Hexagonal bolt	107 735	●			

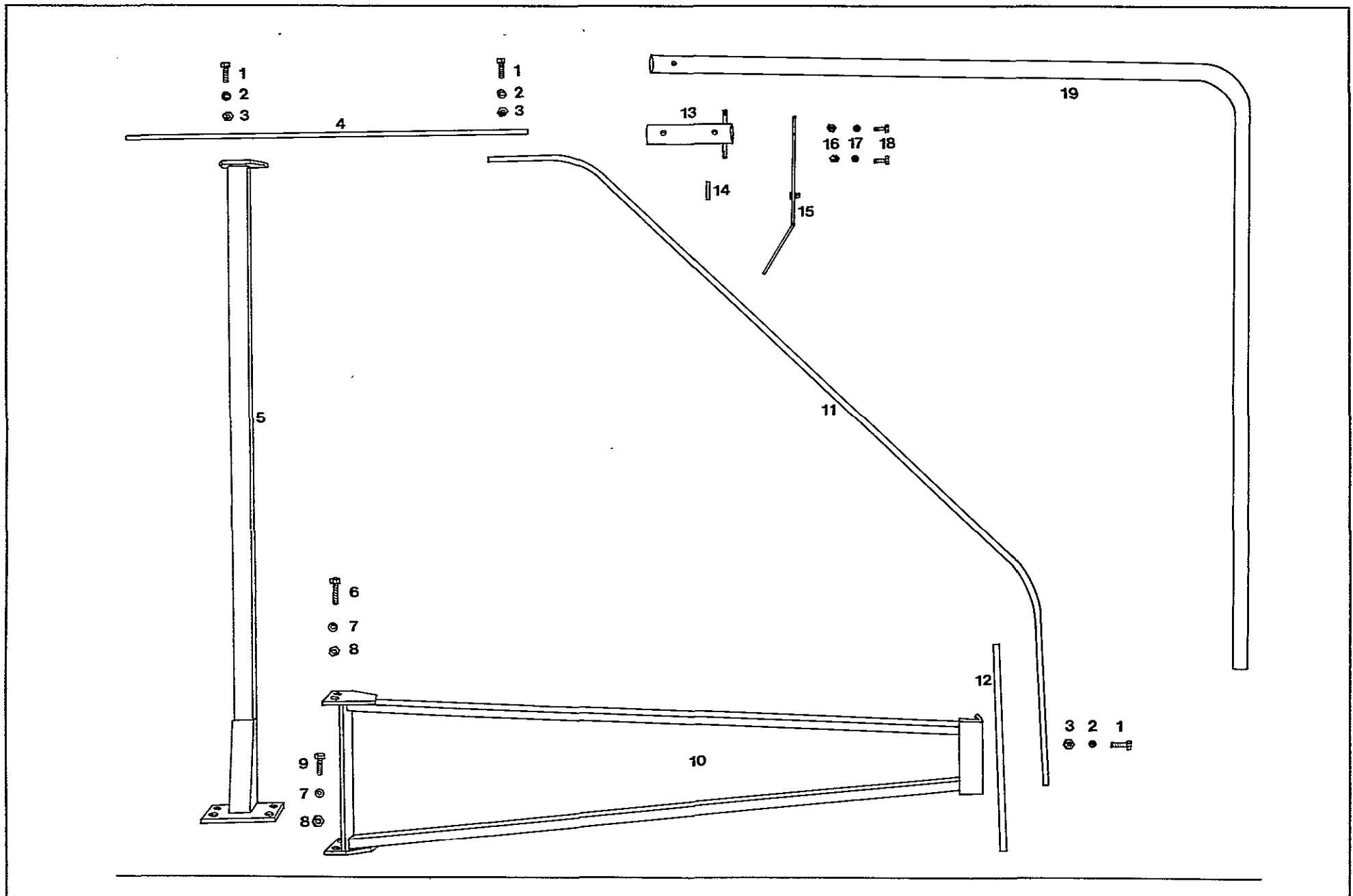

Pos.Nr.	Bezeichnung des Teiles	X = Verschleißteil	* = kein Ersatzteil	Nr.			
Pos.no.	Description of the part.	X = weare part	* = no spare part	No.			
Rep.	Désignation de la pièce	X = pièces d'usure	* = no pièce de rechange	No.			
Pos. no.	Descrizione del pezzo			No.			
	Schutzvorrichtung		Protective device				
	Dispositif de protection						
1	6kt.-Schraube M 10x30 DIN 933-8.8 A1A		Hexagonal bolt	107 735	●		
2	Scheibe 11 DIN 126 ZN 3		Washer	115 983	●		
3	6kt.-Mutter M 10 DIN 6925-8 A1A		Hexagonal nut	108 441	●		
4	Strebe		Strut	492 909	●		
5	Tragrohr		Bracing tube	497 069	●		
6	6kt.-Schraube M 12x45 DIN 931-8.8 A1A		Hexagonal bolt	126 771	●		
7	Scheibe 13 DIN 125 ZN 3		Washer	105 186	●		
8	6kt.-Mutter M 12 DIN 6925-8 A1A		Hexagonal nut	108 589	●		
9	6kt.-Schraube M 12x35 DIN 933-8.8 A1A		Hexagonal bolt	116 629	●		
10	Strebe		Strut	497 089	●		
11	Schutzbogen, hinten		Rear guard	497 036	●		
12	Lasche		Tongue	492 623	●		
13	Scharnierbuchse		Hinge bush	497 081	●		
14	Spannstift 8x65 DIN 1481 ZN 3		Tension pin	107 470	●		
15	Flachfeder		Flat spring	122 425	●		
16	6kt.-Mutter M 8 DIN 6925-8 A1A		Hexagonal nut	108 531	●		
17	Scheibe 8,4 DIN 125 ZN 3		Washer	115 972	●		
18	6kt.-Schraube M 8x20 DIN 933-8.8 A1A		Hexagonal bolt	107 727	●		
19	Schutzbogen		Guard	497 077	●		

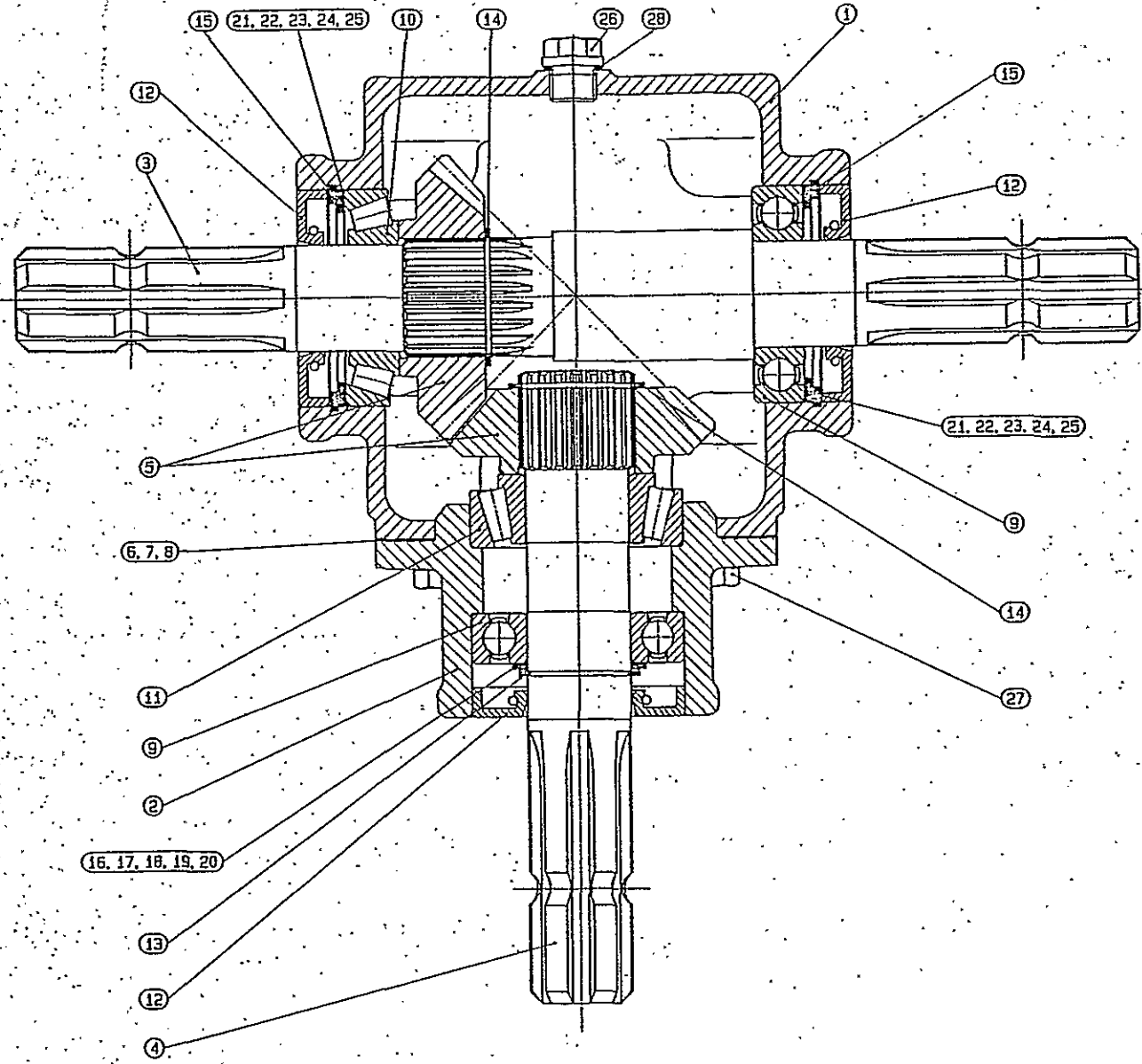

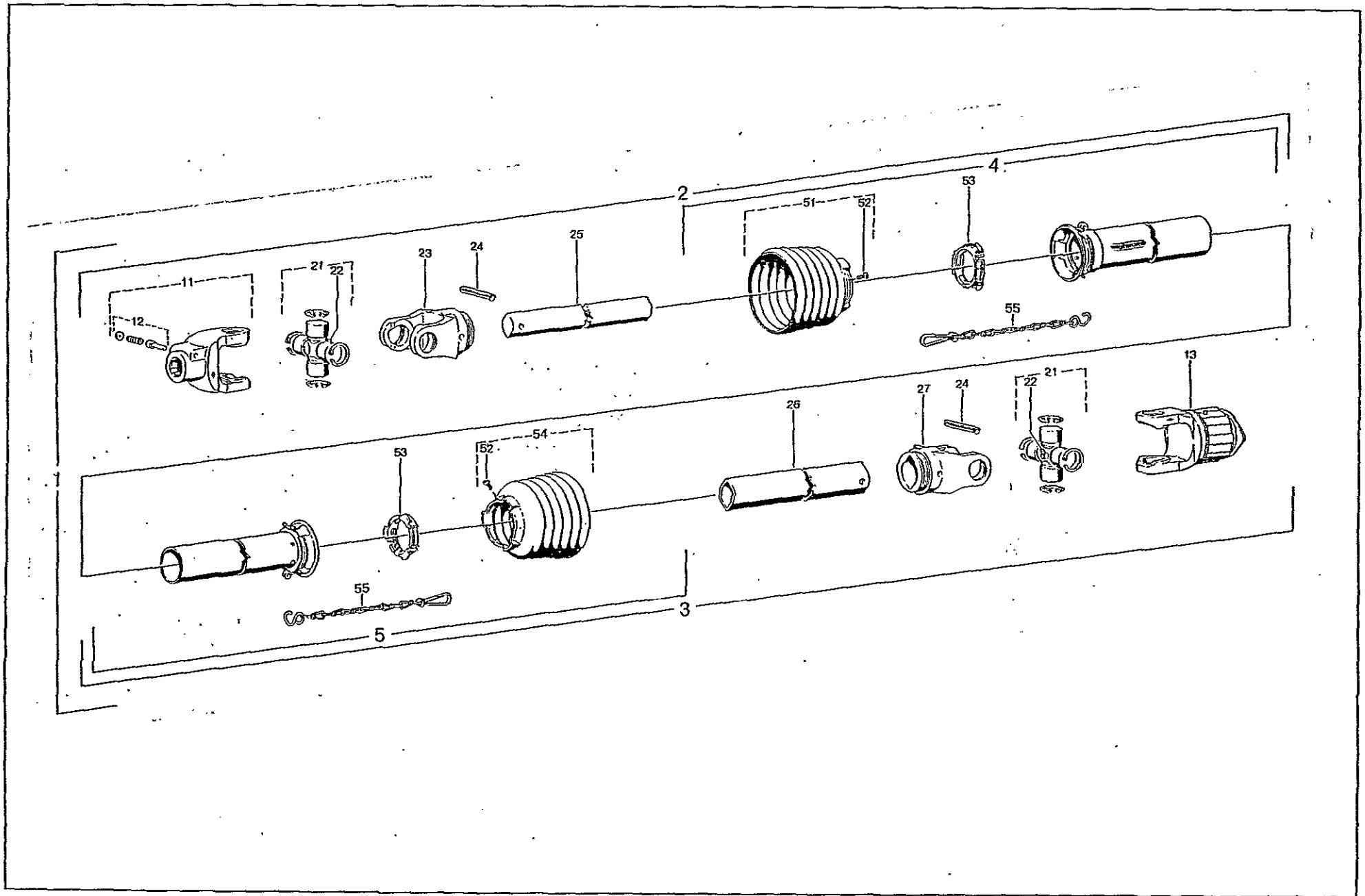

Pos.Nr. Pos.no. Rep. Pos.no.	Bezeichnung des Teiles Description of the part Désignation de la pièce Descrizione del pezzo			Nr. No. No. No.
	Gelenkwelle W 2100-SC05-630-K32B	PTO drive shaft	Transmission	
1	Gelenkwelle mit Schutz W2100-SC05-630-K32B	PTO drive shaft with guard	Transmission avec protecteur	182 710
2	Innere Gelenkwellenhälfte mit äußerer Schutz- hälfte WH 2100-SC05-576	Inner PTO drive shaft half with outer guard half	Demi-transmission intérieure avec demi-protecteur extérieur	182 709
3	Äußere Gelenkwellenhälfte mit innerer Schutz- hälfte WH 2100-SC05-561-K32B	Outer PTO drive shaft half with inner guard half	Demi-transmission extérieure avec demi-protecteur intérieur	182 711
4	Äußere Schutzhälfte SCH05-A 475	Outer guard half	Demi-protecteur extérieur	183 533
5	Innere Schutzhälfte SCH05-J 470	Inner guard half	Demi-protecteur intérieur	183 534
11	Aufsteckgabel, kompl. AG 2100-1 3/8" (6)	Quick-disconnect yoke cpl.	Mâchoire à verrouillage rapide cpl.	040 154
12	Schiebestift, kompl.	Quick-disconnect pin cpl.	Poussoir de verrouillage rapide cpl.	339 107
13	Sternratsche, kompl.; drehsinnunabhängig K32B-2100-1.3/8"(6)ZV; M=400 Nm	Rapidal pin clutch cpl. independet of direction of rotation	Limiteur à cames en étoile cpl. indépendant du sens de rotation	351 075
21	Kreuzgarnitur, kompl.	Cross and bearing kit cpl.	Bloc croisillon cpl.	040 116
22	Kegel-Schmiernippel M 8x1	Lubrication fitting	Graisneur	084 099
23	Rillengabel RG 2100-00a	Inboard yoke	Mâchoire à gorge	040 444
24	Spannstift DIN 1481 8x50	Spring type straight pin	Goupille élastique	020 600
25	Profilwelle 00a-540	Profile shaft	Arbre profilé	050 033
26	Profilrohr 0a-525	Profile tube	Tube profilé	182 712
27	RillengabelRG 2100-0a	Inboard yoke	Mâchoire à gorge	040 456
51	Schutztrichter mit Schraube RP 5	Guard cone with screw	Cône protecteur avec vis	365 258
52	Schraube 4x10	Screw	Vis	365 305
53	Gleitring	Bearing ring	Bague de glissement	359 005
54	Schutztrichter mit Schraube RP 8	Guard cone with screw	Cône protecteur avec vis	365 261
55	Haltekette	Safety chain	Chaînette	044 321
	Ersatzteile können nur über die Firma Walter- scheid bezogen werden.	Spare parts can only be purchased from the walterscheid company.	Les pièces de rechange peuvent seulement être achetées de chez la maison Walterscheid	

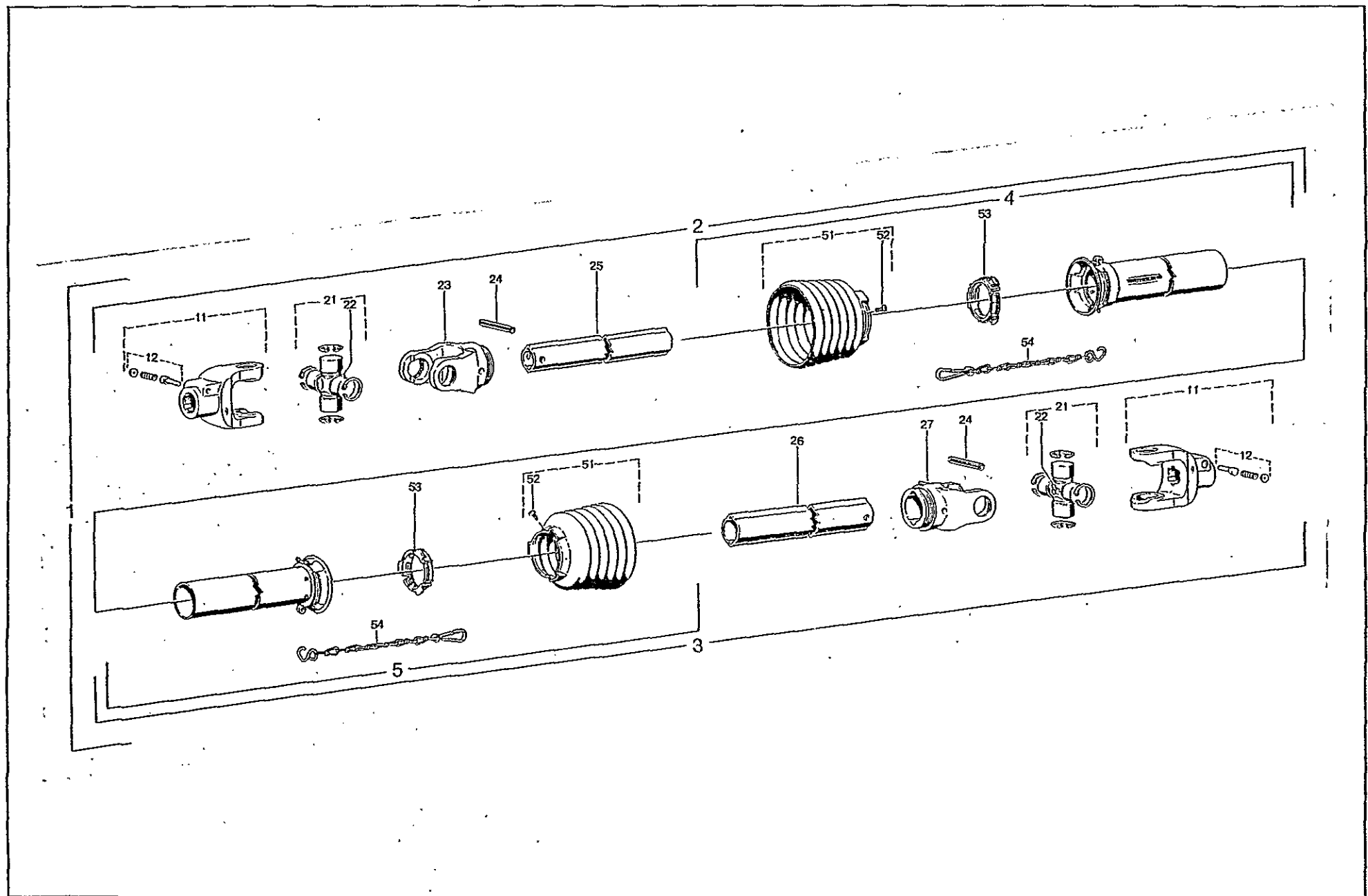

Pos.Nr. Pos.no. Rep. Pos.no.	Bezeichnung des Teiles Description of the part Désignation de la pièce Descrizione del pezzo			Nr. No. No. No.
	Gelenkwelle W 2200-SC15-1410	PTO drive shaft	Transmission	
1	Gelenkwelle mit Schutz W2200-SC15-1410	PTO drive shaft with guard	Transmission avec protecteur	182 715
2	Innere Gelenkwellenhälfte mit äußerer Schutz- hälfte WH 2200-SC15-1340	Inner PTO drive shaft half with outer guard half	Demi-transmission intérieure avec demi-protecteur extérieur	359 938
3	Äußere Gelenkwellenhälfte mit innerer Schutz- hälfte WH 2200-SC15-1335	Outer PTO drive shaft half with inner guard half	Demi-transmission extérieure avec demi-protecteur intérieur	182 713
4	Äußere Schutzhälfte SCH15-A 1240	Outer guard half	Demi-protecteur extérieur	362 622
5	Innere Schutzhälfte SCH15-J 1240	Inner guard half	Demi-protecteur intérieur	183 535
11	Aufsteckgabel, kompl. AG 2200-1 3/8" (6)	Quick-disconnect yoke cpl.	Mâchoire à verrouillage rapide cpl.	041 049
12	Schiebestift, kompl.	Quick-disconnect pin cpl.	Poussoir de verrouillage rapide cpl.	339 107
21	Kreuzgarnitur, kompl.	Cross and bearing kit cpl.	Bloc croisillon cpl.	044 439
22	Kegel-Schmiernippel M 8x1	Lubrication fitting	Graisseur	084 099
23	Rillengabel RG 2200-0v	Inboard yoke	Mâchoire à gorge	041 065
24	Spannstift DIN 1481 10x65	Spring type straight pin	Goupille élastique	020 614
25	Profilwelle Ov-1300	Profile shaft	Arbre profilé	087 879
26	Profilrohr 1-1295	Profile tube	Tube profilé	052 490
27	Rillengabel RG 2200-1	Inboard yoke	Mâchoire à gorge	041 068
51	Schutztrichter mit Schraube RP 5	Guard cone with screw	Cône protecteur avec vis	365 345
52	Schraube 4x10	Screw	Vis	365 305
53	Gleitring	Bearing ring	Bague de glissement	087 279
54	Haltekette	Safety chain	Chainette	044 321
	Ersatzteile können nur über die Firma Walter- scheid bezogen werden.	Spare parts can only be purchased from the walterscheid company.	Les pièces de rechange peuvent seulement être achetées de chez la maison Walterscheid.	

Ersatzteilliste

NUMMERNVERZEICHNIS INDEX OF NUMBERS

LIST NUMERIQUE INDICE PER NUMERI

Bestell-Nr. Part no No de commande No d'ordinazione	Tafel Table Tableau Tavola	Pos.-Nr. Pos.-no No de pos. Pos. No	Bestell-Nr. Part no No de commande No d'ordinazione	Tafel Table Tableau Tavola	Pos.-Nr. Pos.-no No de pos. Pos. No	Bestell-Nr. Part no No de commande No d'ordinazione	Tafel Table Tableau Tavola	Pos.-Nr. Pos.-no No de pos. Pos. No	Bestell-Nr. Part no No de commande No d'ordinazione	Tafel Table Tableau Tavola	Pos.-Nr. Pos.-no No de pos. Pos. No
086 184	5.10		116 630	2.16		122 494	3.27		490 961	5.19	
105 186	2.17	3.15 4.05 5.13	116 686	3.08		122 500	2.26		492 255	4.15	
	8.07		116 699	1.06	2.15	122 501	3.21		492 271	6.15	
105 189	2.18		116 746	4.25		122 511	2.10		492 298	7.23	
106 903	7.19		117 430	2.22		124 131	4.02		492 299	7.22	
106 990	5.18		117 726	3.07		124 151	4.32		492 324	5.01	
107 385	4.34		117 772	2.20		124 279	7.15		492 329	5.04	
107 435	3.31		117 831	4.21	4.27	124 331	4.16	6.02	492 330	5.15	
107 452	1.09	3.26 7.28	118 602	4.30		124 512	7.18		492 361	7.06	
107 454	5.20		118 604	4.14		124 608	5.16		492 377	4.23	
107 464	7.11		118 973	3.11		124 650	4.13		492 385	1.17	
107 465	6.18		120 595	5.21		124 749	5.03		492 569	3.12	
107 470	8.14		120 725	5.17		126 137	2.04		492 623	8.12	
107 727	8.18		120 957	3.33		126 302	4.18		492 856	2.03	
107 735	7.33	8.01	121 024	1.11	3.06 6.19	126 303	4.11		492 857	2.02	
108 292	1.10	4.20 6.20 7.05	121 094	3.32		126 308	3.16	4.06	492 862	7.12	
108 294	3.04		121 327	6.08		126 368	4.32		492 870	3.09	
108 319	4.09		121 349	4.12		126 369	4.32		492 879	4.04	
108 441	2.06	7.31 8.03	121 608	6.10		126 370	4.32		492 881	6.21	
108 455	7.29		121 609	6.14		126 377	3.35		492 883	3.14	
108 531	2.30	3.20 7.02 8.16	121 610	6.13		126 383	3.17		492 884	3.13	
108 544	1.16		121 612	7.25		126 384	4.13		492 886	4.03	
108 589	5.05	5.12 8.08	121 801	3.34		126 385	4.13		492 887	3.30	
109 162	1.04		121 914	4.12		126 417	4.07		492 891	3.29	
109 171	3.25		121 968	7.24		126 771	8.06		492 892	7.01	
109 175	2.25		121 970	7.10		126 880	1.14	3.01	492 900	4.29	
109 585	4.31		121 990	4.22		126 881	1.15	3.02	492 901	4.29	
111 895	1.01		122 079	4.10		126 920	6.01		492 903	2.12	
115 970	7.21		122 103	7.26		126 921	6.07		492 907	4.24	
115 972	2.31	7.03 8.17	122 150	3.23		126 926	2.23		492 909	8.04	
115 979	1.07	2.14 3.36 7.07	122 205	2.27		126 927	2.24		492 913	7.13	
115 983	2.05	7.32 8.02	122 294	3.18		126 929	1.12	3.03	492 916	7.14	
116 007	2.21		122 333	3.24		127 006	6.22		492 934	4.19	
116 015	6.05		122 334	3.05		224 473	3.10	6.17	492 942	1.03	
116 024	4.01	7.09	122 335	3.28		240 309	6.11		492 945	1.18	
116 043	4.17		122 353	1.13		460 262	6.03		492 954	1.05	
116 534	5.08		122 425	8.15		464 006	6.09		497 027	4.08	
116 587	1.08	2.13	122 442	2.11		478 677	3.22		497 028	6.06	
116 608	7.17		122 460	6.16		486 050	2.19		497 032	5.09	
116 609	7.20		122 469	3.19		486 195	1.02		497 036	8.11	
116 612	7.04		122 471	2.28		486 545	5.06		497 043	7.27	
116 614	2.32		122 477	6.04		486 848	5.07		497 044	7.16	
116 627	5.14		122 491	2.09		488 456	6.12		497 047	7.30	
116 629	8.09					490 072	5.11				
						490 920	4.33				

